

VM 900

NOTICE D'UTILISATION
GEBRAUCHSANWEISUNG
OPERATING INSTRUCTIONS
ISTRUZIONI PER L'USO
MODO DE EMPLEO

GEBRUIKSHANDLEIDING
BRUGSANVISNING
MANUAL DE UTILIZAÇÃO
INSTRUKCJA UŻYTKOWANIA

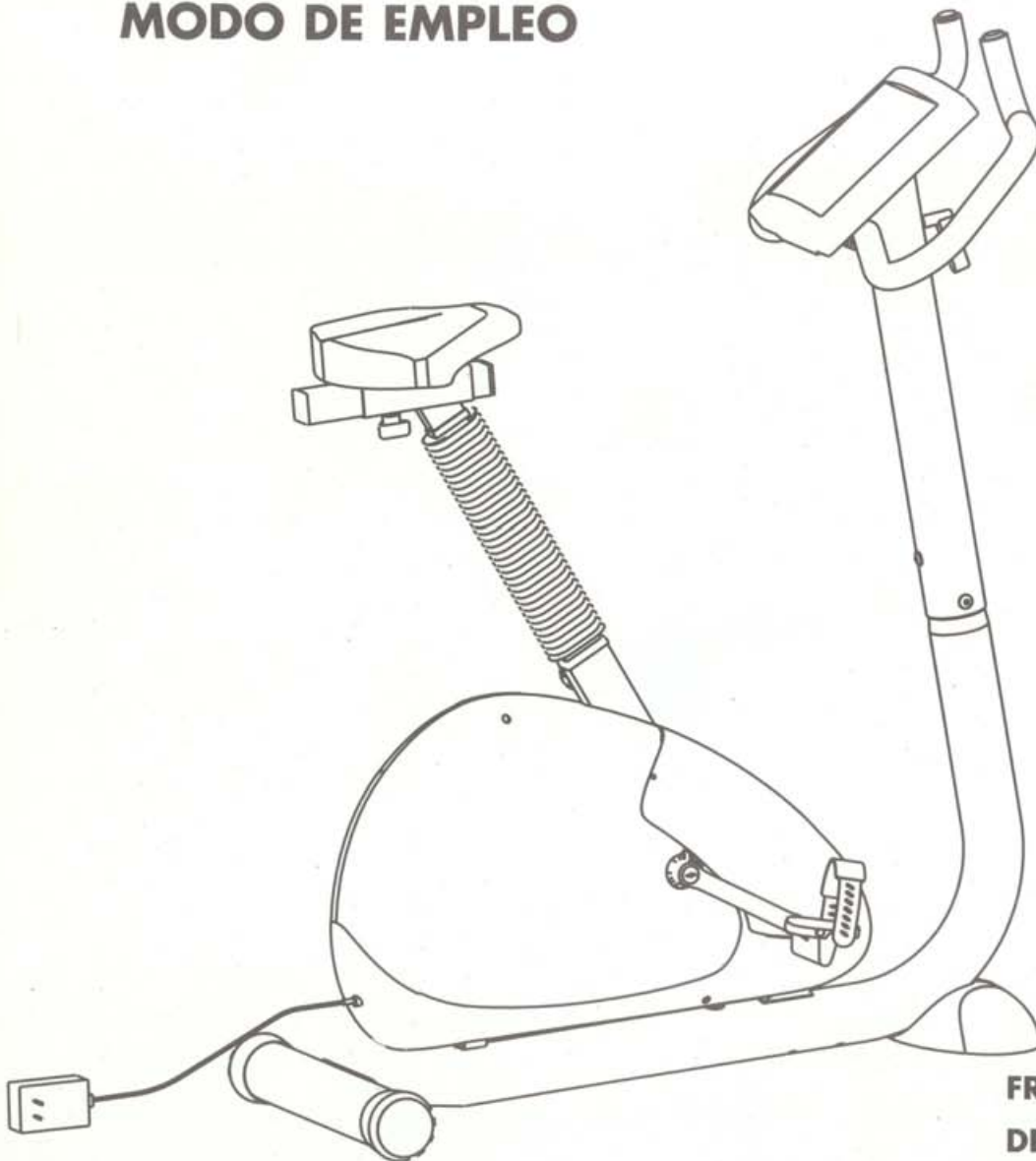

FRANÇAIS	p 7
DEUTSCH	p 9
ENGLISH	p 11
ITALIANO	p 13
ESPAÑOL	p 15
NEDERLANDS	p 17
DANSK	p 19
PORTUGUÊS	p 21
WJĘZYKU POLSKIM	p 23

DOMYOS

DECATHLON

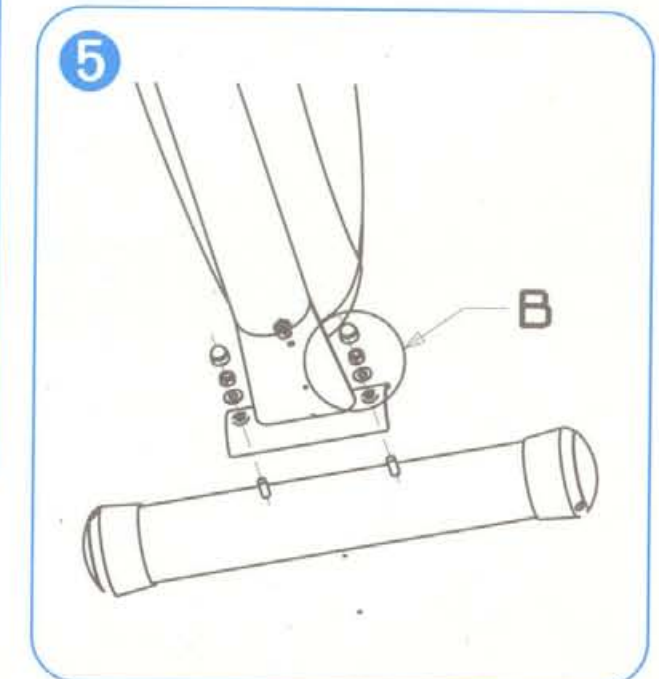
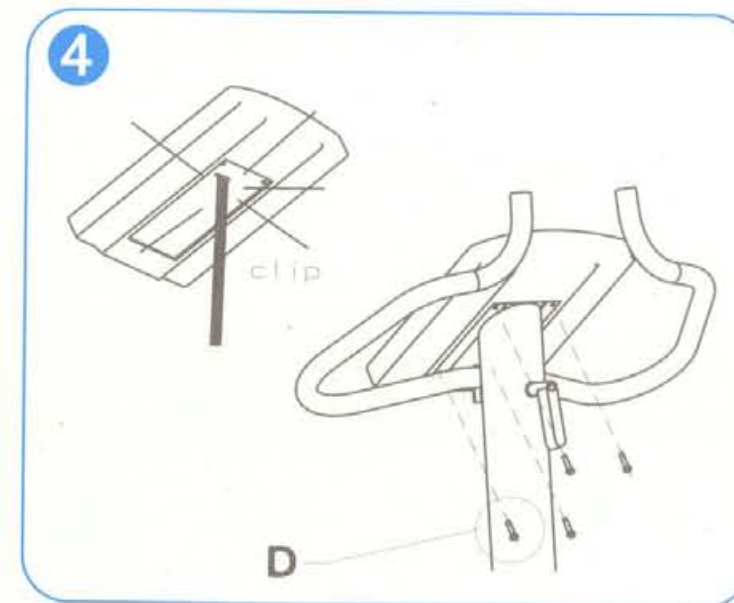
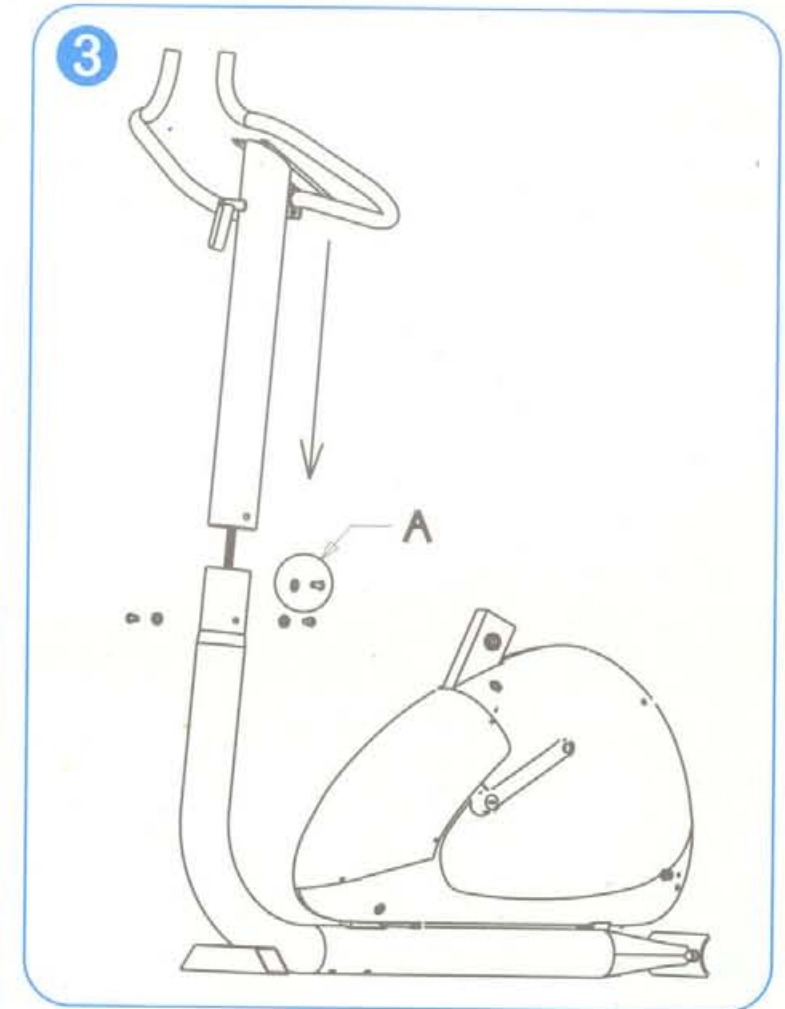
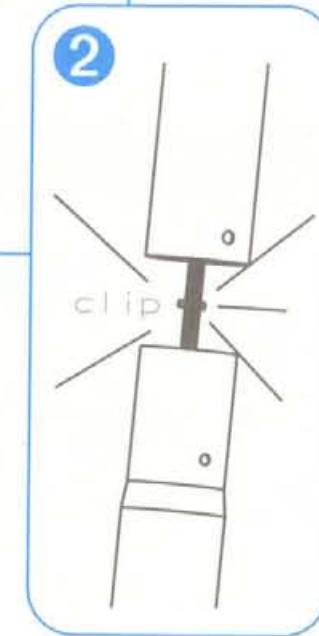
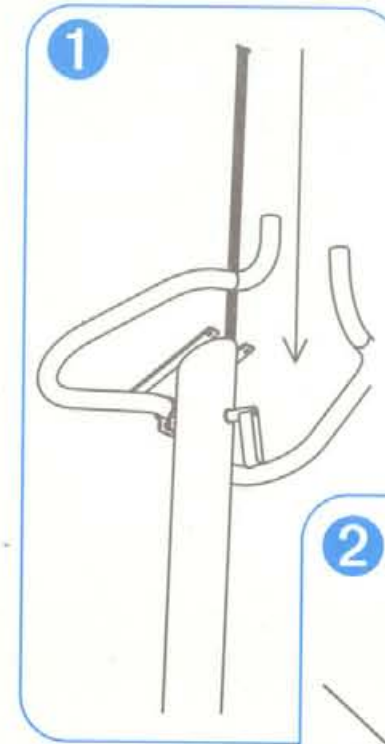
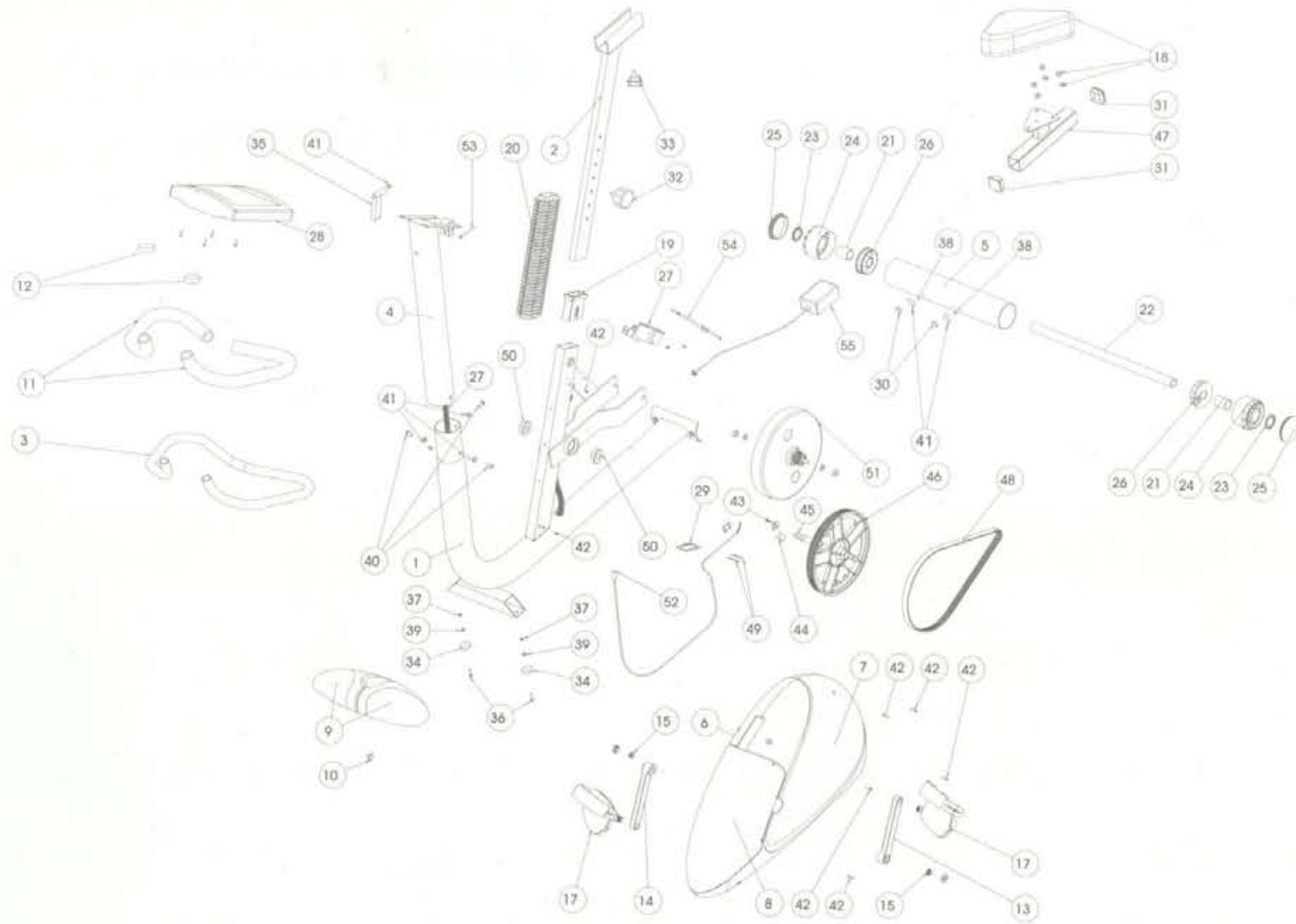

Repère Marker Markierung Riferimento Referencia Item Indice Tabellnummer Oznaczenia	Référence Item Seria Warencode Codice articolo Artikelcode Código Kode	Quantité Quantity Menge Cantidad Hoeveelheid Quantidade Mengde Ilość	Repère Marker Markierung Riferimento Referencia Item Indice Tabellnummer Oznaczenia	Référence Item Seria Warencode Codice articolo Artikelcode Código Kode	Quantité Quantity Menge Cantidad Hoeveelheid Quantidade Mengde Ilość	Repère Marker Markierung Riferimento Referencia Item Indice Tabellnummer Oznaczenia	Référence Item Seria Warencode Codice articolo Artikelcode Código Kode	Quantité Quantity Menge Cantidad Hoeveelheid Quantidade Mengde Ilość
1	7/182147	1	17	9/224793	2	33	3/225259	1
2	7/308337	1	18	3/206157	1	34	7/581238	2
3	7/308175	1	19	3/215881	1	35	6/754465	1
4	2/342421	1	20	3/215911	1	43	5/448522	2
5	6/839096	1	21	5/377137	2	44	6/711448	1
6	0/252131	1	22	3/207692	1	45	3/206785	1
7	9/252134	1	23	5/382149	2	46	3/207013	1
8	4/342674	1	24	5/378605	2	47	3/195805	1
9	3/400085	1	25	2/194414	2	48	7/308310	1
10	2/308223	1	26	5/378621	2	50	6/710662	2
11	4/205871	1	27	1/334360	1	51	9/421726	1
12	0/799688	2	28	1/339346	1	52	7/343760	1
13	4/328957	1	30	7/581688	2	53	7/350643	1
14	4/205774	1	31	7/553676	2	54	7/187106	1
15	0/269638	2	32	4/184955	1	55	2/343754	1

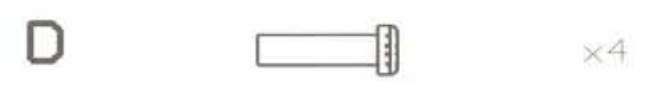
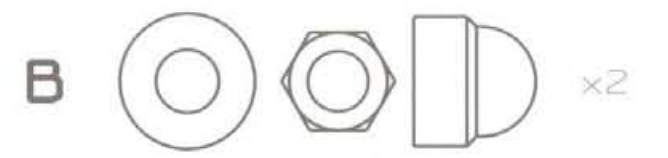
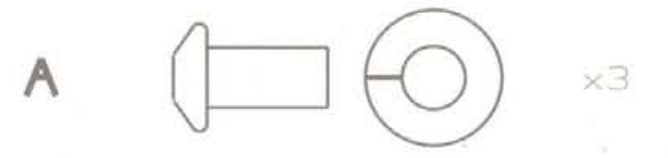
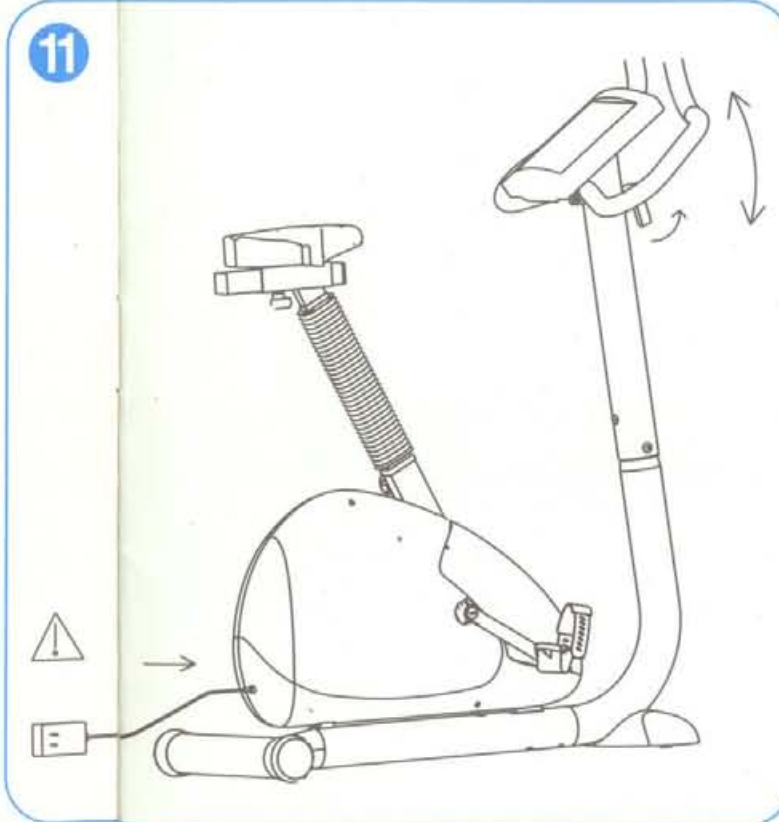
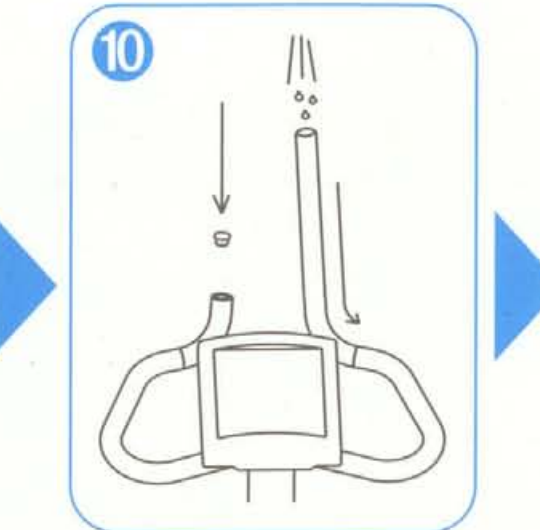
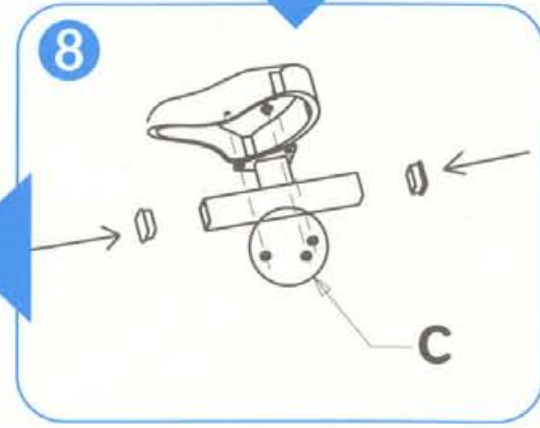
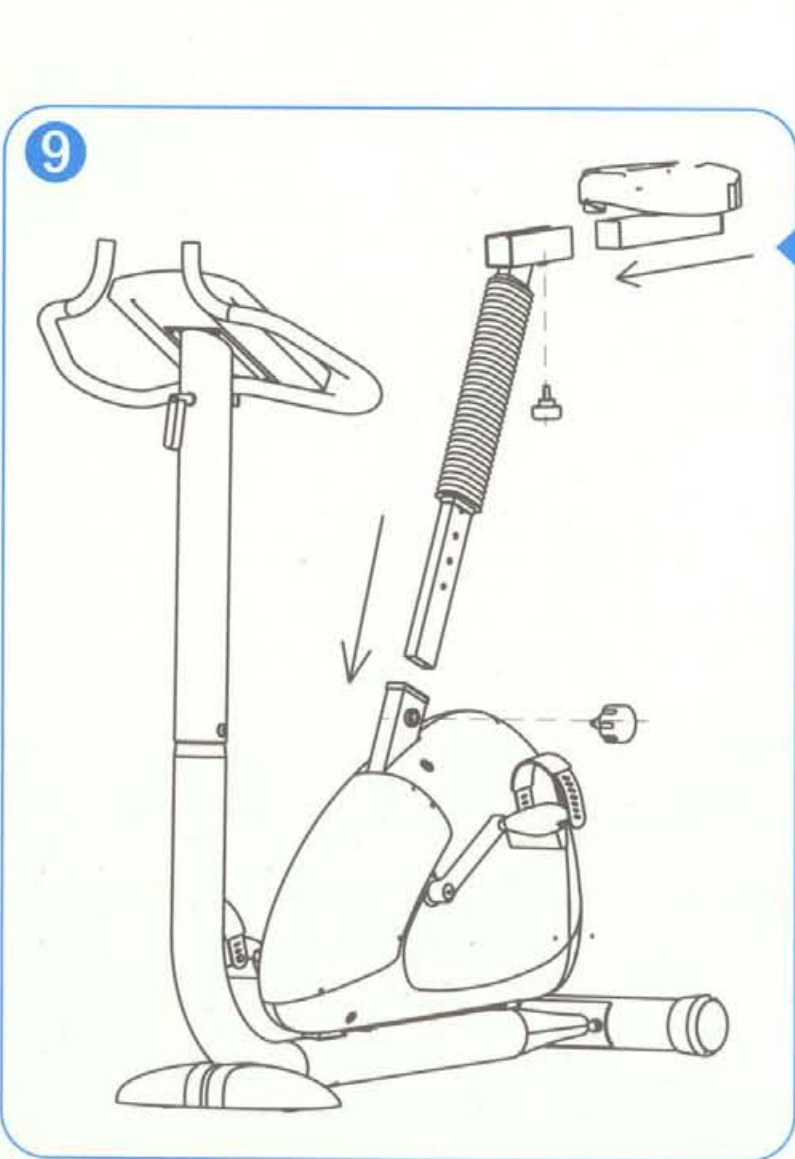
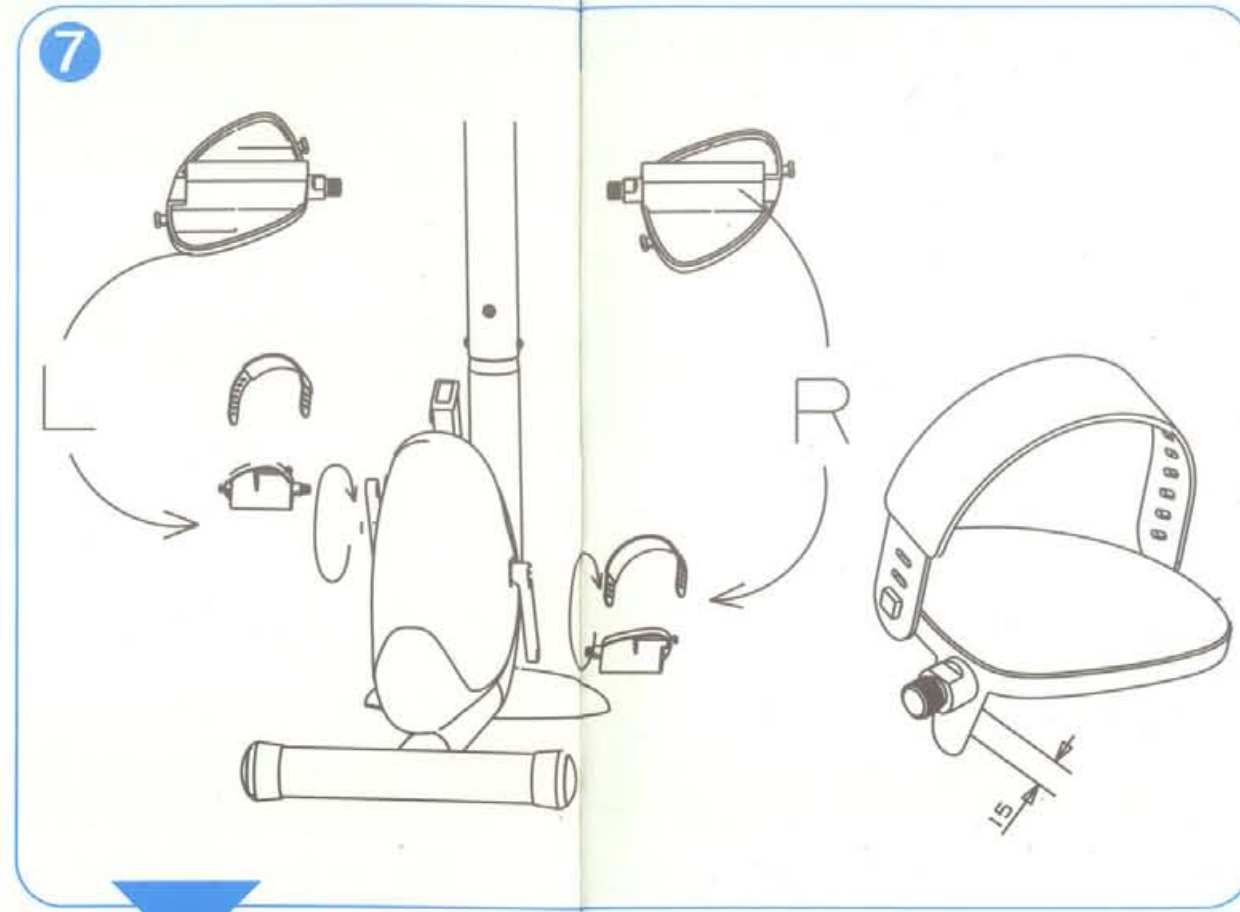
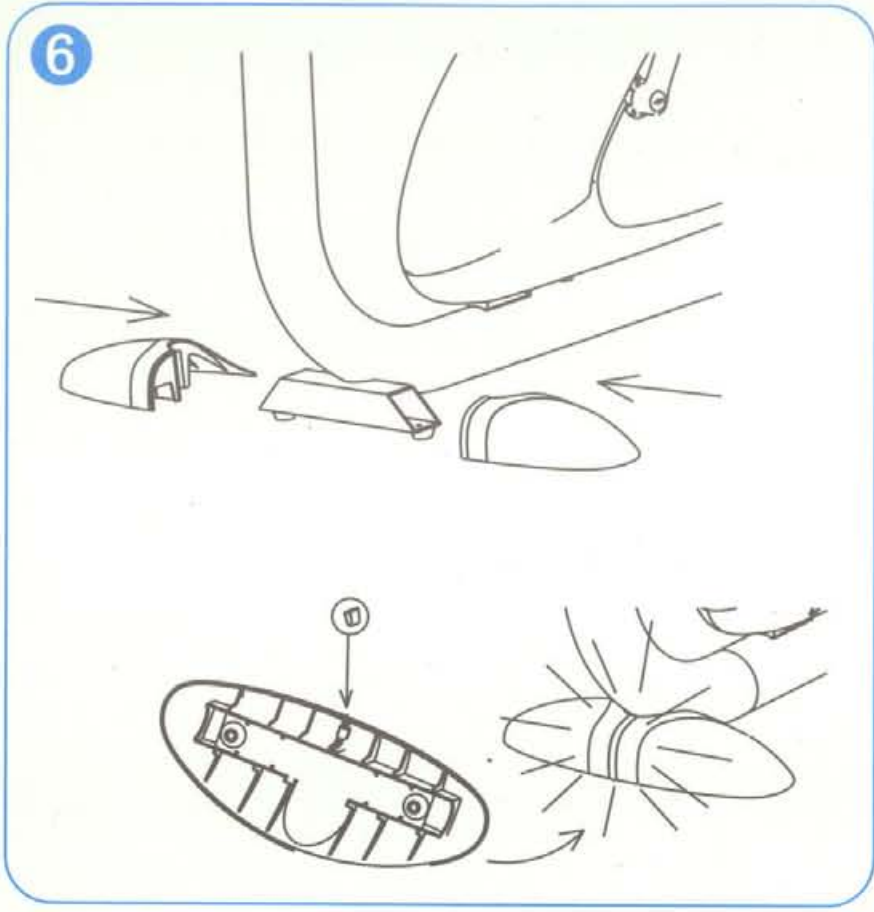

You have chosen a DOMYOS brand Fitness machine. We thank you for the confidence that you have placed in us. We have created the DOMYOS brand to allow all sports persons to keep fit. This is a product created by sports persons for sports persons. We welcome your comments and suggestions concerning DOMYOS products. Your shop team, as well as the DOMYOS design department team, are ready to listen. If you wish to write to us, you may use the attached coupon, or send us an e-mail at the following address : domyos@decathlon.fr

We wish you well with your workout and we hope that this DOMYOS fitness product will bring you pleasure.

INTRODUCTION

The VM900 is a new generation fitness bike. This bike places you in an anatomical position with the back straight and the arms relaxed. This product is equipped with a magnetic transmission system for comfortable and jerk free pedal action.

SAFETY

- This equipment must be assembled by an adult.
- Install your exercise bike in a room which is large enough for it to be used in complete safety.
- Install the VM900 on a firm base and on a level floor.
- Read the recommendations and the exercises carefully before starting your fitness training.
- Do not allow children to play near the equipment whilst you are exercising.
- Do not allow children to use this equipment.
- This equipment conforms to the norm EN-957 class H which concerns equipment intended for use in the home.
- Before undertaking any physical training, you must consult a doctor to make sure that he does not advise against it.
- Suitable for those weighing less than 110 kg.

CARE

The parts and fixing elements must be checked before each use. Replace any faulty part immediately and do not use the bicycle until it has been repaired. Do not store the VM900 in a damp place. (e.g. beside a swimming pool, bathroom...)

SETTINGS

The saddle height can be quickly adjusted. Unscrew the knob, pull on the knob and slide the saddle stem. The knob must engage at the required level. Screw back the knob to avoid any movement.

PARTS OF THE BODY WORKED ON

The exercise bike is an excellent cardio-training activity. The exercise undertaken on this apparatus is intended to increase your cardio-vascular capacity. On the basis of this principle, you improve your physical condition as well as your stamina, and you burn calories. (essential exercise whilst following a diet for weight loss.)

The exercise bike helps to tone the legs and the buttocks. The calf muscles and the lower abdominal muscles are also exercised.

USE

Adjust the height of the saddle by stretching your leg with the knee slightly bent and the middle of your foot just reaching the pedal in the lower position.

If you are a beginner, start by exercising for several days with a slight resistance and weak pedal action, without forcing, and resting if necessary. Gradually increase the number and length of your exercise sessions.

MAINTENANCE / WARM UP :

Start with 10 minutes and gradually build up.

For maintenance work which is intended for maintaining fitness or for physiotherapy, you can exercise every day for about ten minutes. This type of exercise is intended to stimulate your muscles and joints or it can be used as a warm up prior to physical exercise.

To increase tonicity of the legs, choose a greater resistance and increase the exercise time.

Obviously, you can vary the pedal resistance throughout your exercise session.

AEROBIC WORK FOR GETTING FIT :

Moderate effort for a fairly long period (35min to 1 hour).

If you want to lose weight, this type of exercise in conjunction with diet, is the only means of increasing the amount of energy used by the body. To achieve this, it is no use forcing yourself beyond these limits since the best results are obtained through regular exercise.

Choose a relatively weak pedal resistance and exercise at your own pace for a minimum of 30 minutes. This exercise must induce a slight sweating but must not make you breathless. It is the length and slow pace of the exercise which will cause your body to dip into your fat reserves to gain energy, providing you pedal for more than 30 minutes, three times per week minimum.

AEROBIC EXERCISE FOR ENDURANCE :

Sustained effort for 20 to 40 minutes

This type of exercise is intended to significantly strengthen the cardiac muscle and improve respiration.

The resistance and/or pedal speed is increased so as to increase the respiratory rate during the exercise. The effort required is more sustained than that required for the workout for getting fit.

As you progress in your training, you will be able to sustain this effort over a longer period, at a better rate, or with a higher resistance. You can exercise for a minimum of three times per week for this type of workout.

Exercise at a more forced pace (anaerobic work and work in the red zone) is reserved for athletes and requires a preparation adapted to this purpose.

After each exercise session, spend several minutes reducing the pedal speed and the resistance so as to calm down the body and gradually return it to a relaxed state.

WARRANTY

The Domyos VM900 is guaranteed 5 years against any flaws that may be the result of a manufacturing or material defect. This guarantee only covers private use within the home. The wearing parts and the electronics are guaranteed for 2 years.

CARDIO - TRAINING

CARDIO-TRAINING EXERCISE

Cardio-training exercise is a form of aerobics (conditioning the body in the presence of oxygen) and allows you to improve your cardio-vascular capacity. To be more precise, you will improve the tonicity of the heart and your blood vessels. Cardio-training exercise carries the oxygen breathed in from the air to your muscles. It is the heart that pumps this oxygen through the body and, in particular, to the muscles being exercised.

CONTROLLING YOUR HEARTBEAT

It is vital to measure your pulse periodically in order to control your degree of exercising. If you do not have an electronic measuring device, follow this procedure :

To take your pulse, position two fingers : on the neck, or below the ear, or at the inside wrist beside the thumb.

Do not press too hard : excessive pressure reduces the blood flow and

can slow down the heartbeat. After counting the pulsations for 30 seconds, multiply by 2 to obtain the number of pulsations per minute.

Example : 75 pulsations counted in 30 seconds corresponds to a heart beat of 150 pulsations per minute.

PHASES OF A PHYSICAL ACTIVITY

A Warm-up phase : progressive effort.

Warming up is a preparatory phase before any activity. It puts the person INTO OPTIMUM CONDITIONS for carrying out his or her favorite sport. It is a METHOD OF PREVENTING ACCIDENTS TO TENDONS AND MUSCLES. There are two aspects : WAKING UP THE MUSCULAR SYSTEM, GENERAL WARMING UP.

1) The muscular system is prepared in a SPECIAL STRETCHING SESSION which PREPARES FOR EACH ACTIVITY : each group of muscles is used, joints are used.

2) Global warming up gradually brings the cardiovascular and respiratory system into action, improves irrigation of the muscles and prepares for making efforts. It must be sufficiently long : 10 min for a leisure sport activity, 20 min for a competition sport activity. Note that warming up must be longer : after 55 years old, in the morning.

B Training

TRAINING is the main phase of your physical activity. You can improve your physical condition by REGULAR training.

- Anaerobic exercise to develop endurance.
- Aerobic exercise to develop cardio-pulmonary resistance.

C Slowing down

This is the continuation of an activity at low intensity, the gradual "return to rest" phase. SLOWING DOWN brings the cardiovascular and respiratory system, the blood flow and muscles back to "normal" (eliminating the counter effects of an exercise, such as lactic acids, the accumulation of which is one of the major causes of muscular pains such as cramps and stiff muscles).

D Stretching

STRETCHING must follow the slowing down phase while joints are still warm in order to reduce risks of injury. Stretching after an activity : minimizes MUSCULAR STIFFNESS due to an accumulation of LACTIC ACIDS, "stimulates" BLOOD CIRCULATION.

Exercise range

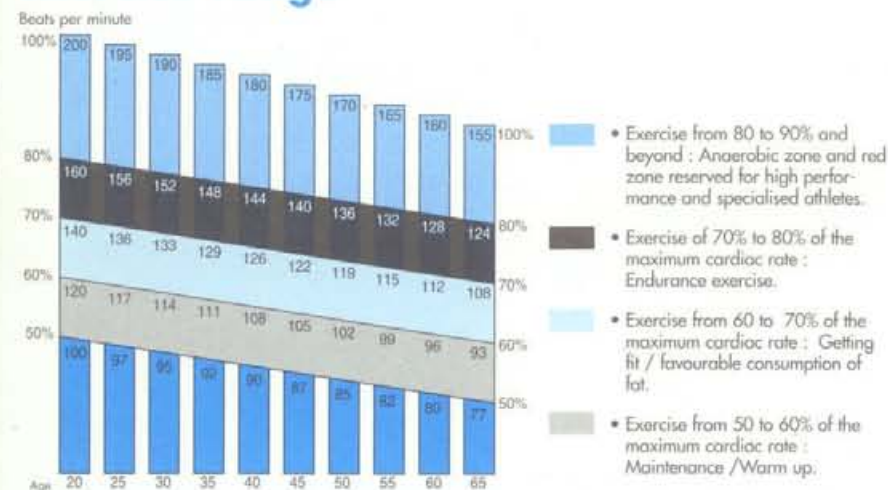

WARNING, TECHNICAL INSET WARNING TO USERS

You must work towards getting fit in a controlled manner.

Do not hesitate to consult a doctor before any physical activity, especially if : you have not practiced any sports activities in recent years, you are more than 35 years old, you are not sure about your health, you are following medical treatment.

CONSULT A DOCTOR BEFORE PRACTISING ANY SPORT.