

# AB 600

# AB 600

Keep these instructions  
Notice à conserver  
Conservar instrucciones  
Bitte bewahren Sie diese Hinweise auf  
Istruzioni da conservare  
Bewaar deze handleiding  
Instruções a conservar  
Zachowaj instrukcję  
Őrizze meg a használati útmutatót  
Сохранить инструкцию  
Păstrați instrucțiunile  
Návod je potrebné uchovať  
Návod je třeba uchovat  
Spara bruksanvisningen  
Запазете упътването  
Bu kılavuzu saklayınız  
Збережіть цю інструкцію  
دليل يجب الاحتفاظ به  
请妥善保存说明书

**OPERATING INSTRUCTIONS  
NOTICE D'UTILISATION  
MODO DE EMPLEO  
GEBRAUCHSANWEISUNG  
ISTRUZIONI PER L'USO  
GEBRUIKSHANDLEIDING  
MANUAL DE UTILIZAÇÃO**

**INSTRUKCJA UŻYTKOWANIA  
HASZNÁLATI ÚTMUTATÓ  
ИНСТРУКЦИЯ ПО ИСПОЛЬЗОВАНИЮ  
INSTRUCȚIUNI DE UTILIZARE  
NÁVOD NA POUŽITIE  
NÁVOD K POUŽITÍ  
BRUKSANVISNING**

**УПЪТВАНЕ ЗА ИЗПОЛЗВАНЕ  
KULLANIM KILAVUZU  
ІНСТРУКЦІЯ ВИКОРИСТАННЯ  
دليل الاستخدام  
使用说明**

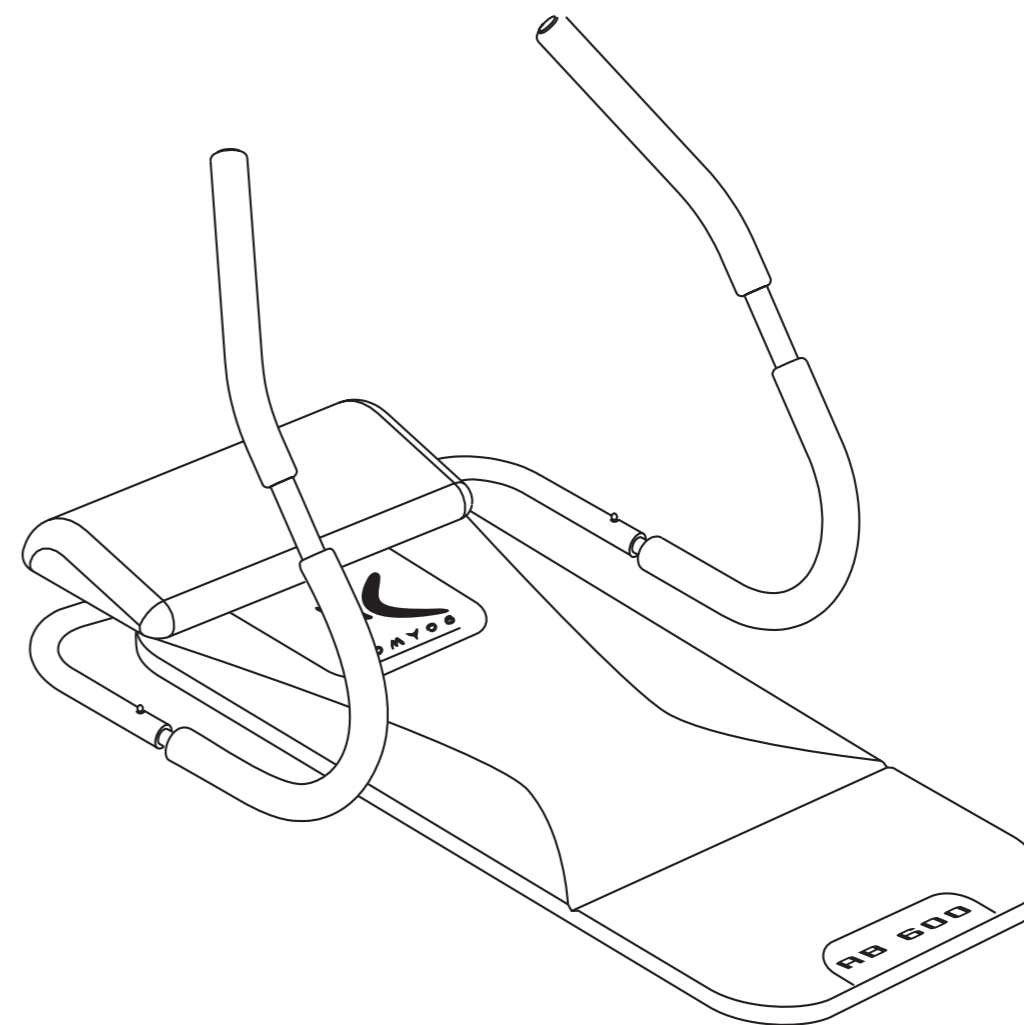

 **DOMYOS**

TURKSPORT Spor Ürünleri Sanayi ve Ticaret Ltd.Şti - Mega Center C 36 Blok D: 374 Bayrampaşa - 34235 Istanbul - Turkey

ИМПОРТЕР : ООО «Октобл», 141031, Россия, Московская область, Мытищинский район, МКАД 84-й км., ТПЗ «Алтуфьево», владение 3, строение 3



[www.domyos.com](http://www.domyos.com) OXYLANE 4, bd de Mons - BP 299 - 59665 Villeneuve d'Ascq Cedex - France  
Made in Taiwan - Fabricado em Taiwan - 台湾制造 - Произведено на Тайване - İmal edildiği yer Tayvan  
Réf. Pack : 1226.964 - IMPORTADO PARA O BRASIL POR IGUASPORT Ltda - CNPJ : 02.314.041/0001-88 - 合格品

 **DOMYOS**

ASSEMBLY • MONTAGE • MONTAJE • MONTAGE • MONTAGGIO • AFWERKING • MONTAGEM  
 • MONTAŽ • SZERELÉS • СБОРКА • MONTARE • MONTÁŽ • MONTÁŽ • MONTERING •  
 МОНТИРАНЕ • MONTAJ • МОНТУВАННЯ • التركيب • 安装

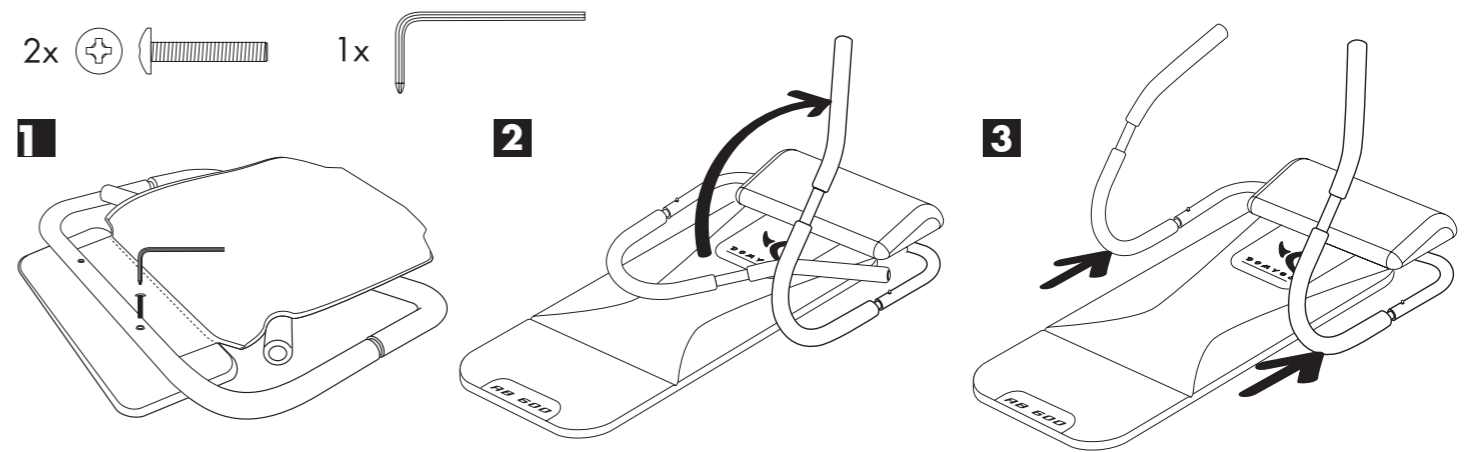

FOLDING - PLIAGE - PLEGADO - ZUSAMMENKLAPPEN -  
 - SKŁADANIE - ÖSSZECSUKÁS - Складывание - PLIERE -  
 СГЪВАНЕ - КАТЛАМА - СКЛАДАННЯ - الطي - 折迭

CHIUSURA - OPKLAPPEN - DOBRAGEM  
 SKŁADANIE - SKLÁDÁNÍ - ИНОПВИКНИНГ -

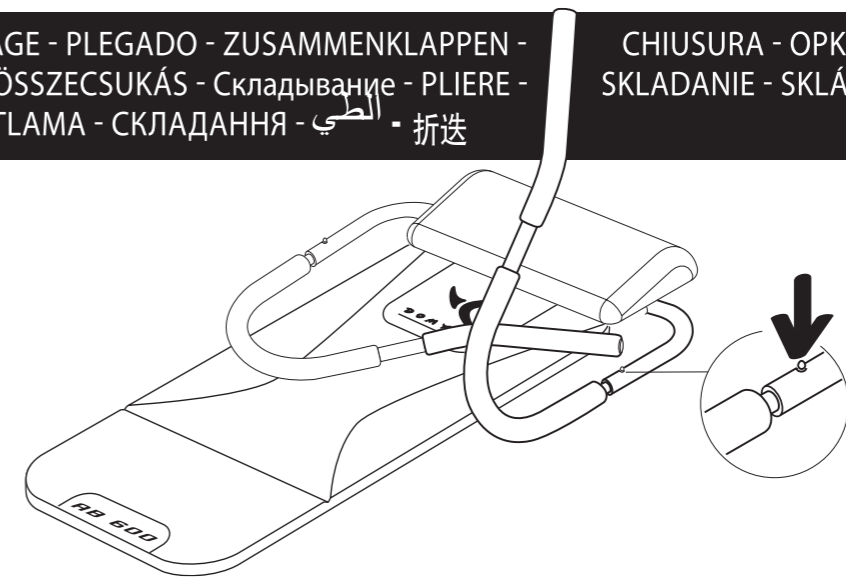

EXERCICES - EXERCICES - EJERCICIOS - ÜBUNGEN - ESERCIZI - OEFENINGEN  
 EXERCÍCIOS - ĆWICZENIA - GYAKORLATOK - УПРАЖНЕНИЯ - ЕХЕРСІТІ - CVIKY - CVIČENÍ  
 KROPPSÖVNINGAR - УПРАЖНЕНИЯ - EGZERSÍZLER - ВПРАВИ - العربية - 中文



Head rest  
Appui-tête  
Reposacabezas  
Kopfstütze  
Poggiatesta  
Hoofdsteun  
Apoio para a cabeça  
Podgłówek  
Fejtámasz  
Подголовник  
Suport pentru cap  
Opierka hlavy  
Podrperka hlavy  
Nackstöd  
Облегалка за главата  
Başlık  
Підголівник  
مسند الرأس  
头枕

Handles  
Poignées  
Empuñaduras  
Griffe  
Impugnatura  
Handvaten  
Pegas  
Uchwyty  
Fogantyúk  
Ручки  
Mânere  
Růčky  
Držadla  
Handtag  
Ръкохватки  
Tutma kolları  
Рукоятки  
المقابض  
把手

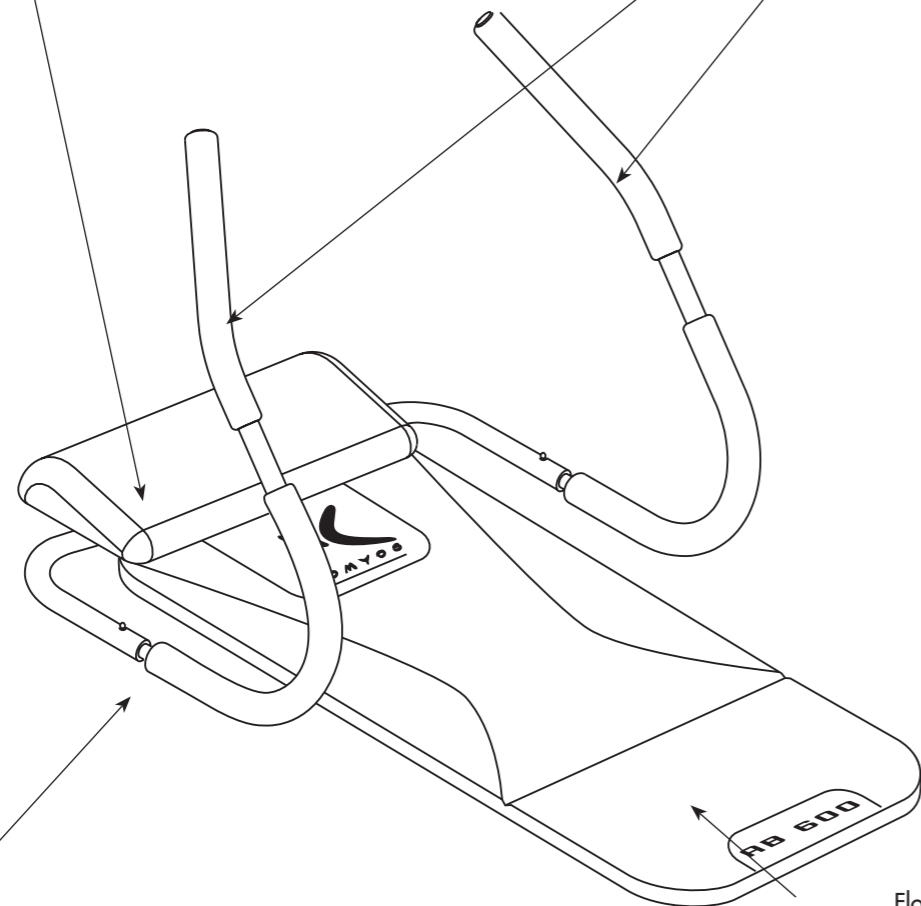

Folding system  
Système de pliage  
Sistema de doblado  
Klappsystem  
Sistema di chiusura  
Vouwstelsysteem  
Sistema de dobragem  
System składania  
Összecsukó rendszer  
Складные системы  
Sistem de pliere  
Skladací systém  
Skládací systém  
Viksystem  
Система за съгване  
Katlama sistemi  
Система складання  
نظام الطي  
折疊式系統

Floor mat (back protection)  
Tapis de sol (protection pour le dos)  
Tapiz de suelo (protección para la espalda)  
Matte (Schutz für den Rücken)  
Tappeto da pavimento (protezione per la schiena)  
Mat (bescherming van de rug)  
Tapete do chão (protecção para as costas)  
Dywanik (dla zabezpieczenia pleców)  
Talaizszőnyeg (a hát védelmére)  
Напольное покрытие (защита для спины)  
Covor pentru sol (protecție pentru spate)  
Koberec (ochrana chrbta)  
Podlahový koberec (ochrana pro záda)  
Golvmatta (skydd för ryggen)  
Подова настилка /защита за гърба/  
Zemin halısı (sirt için koruma)  
Захисний килим  
(لحمایة الظهر)  
地墊 (保护背部)

	<b>AB 600</b>	<b>3,8 kg</b> <b>8,4 lbs</b>
	<b>91 x 60 x 64 cm</b> <b>35,8 x 23,6 x 25,2 inch</b>	



**WARNING**

- Misuse of this product may result in serious injury.
- Read user's manual and follow all warnings and operating instructions prior to use.
- Do not allow children on or around machine.
- Replace label if damaged, illegible, or removed.
- Keep hands, feet and hairs away from moving parts.

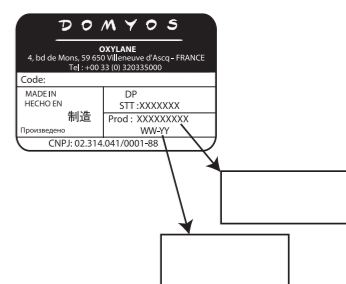
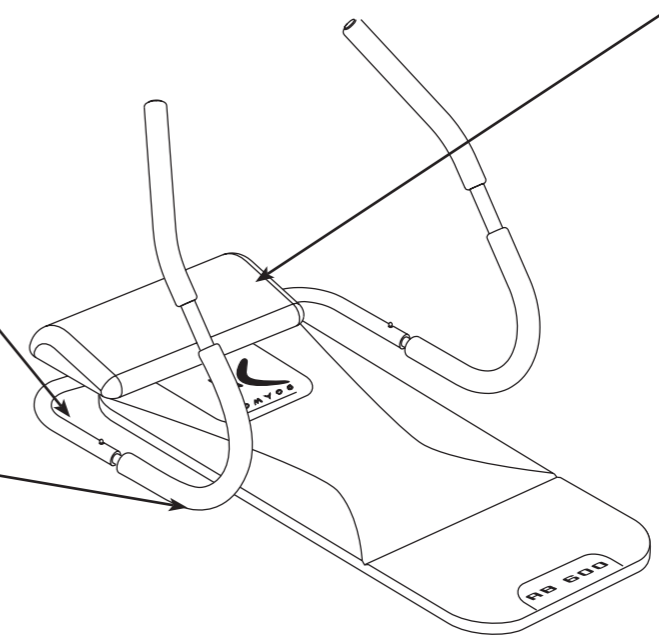

**AVERTISSEMENT**

- Tout usage impropre de ce produit risque de provoquer des blessures graves.
- Avant toute utilisation, veuillez lire attentivement le mode d'emploi et respecter l'ensemble des avertissements et instructions qu'il contient.
- Ne pas permettre aux enfants d'utiliser cette machine et les tenir éloignés de cette dernière.
- Si l'autocollant est endommagé, illisible ou manquant, il convient de le remplacer.
- Ne pas approcher vos mains, pieds et cheveux de toutes les pièces en mouvement.

**ADVERTENCIA**

- Cualquier uso impropio de este producto puede provocar heridas graves.
- Antes de cualquier utilización, lea atentamente el modo de empleo y respetar todas las advertencias e instrucciones que contiene.
- No permitir a los niños utilizar esta máquina y mantenerlos alejados de la misma.
- Si faltase la pegatina, o si la misma estuviera dañada o ilegible, conviene sustituirla.
- No acercarse sus manos, pies y cabello de todas las piezas en movimiento.

**WARNHINWEIS**

- Jede unsachgemäße Benutzung dieses Produktes kann schwere Verletzungen zur Folge haben.
- Vor jedem Gebrauch bitte diese Gebrauchsanweisung aufmerksam lesen und alle darin enthaltenen Warnhinweise und Anweisungen befolgen.
- Kindern ist die Benutzung dieser Maschine zu untersagen und sie sind davon fernzuhalten.
- Ist der Aufkleber beschädigt, unleserlich oder nicht mehr vorhanden, muss er ersetzt werden.
- Ihre Hände, Füße und Haare von allen drehenden Teilen fernhalten.

**AVVERTENZA**

- Ogni uso improprio del presente articolo rischia di provocare gravi incidenti.
- Prima di qualsiasi utilizzo, vi preghiamo di leggere attentamente le istruzioni per l'uso e di rispettare le avvertenze e le modalità d'impiego.
- Tenere i bambini lontani dalla macchina e non permettere loro di utilizzarla.
- Se l'etichetta è danneggiata, illeggibile o assente, occorre sostituirla.
- Non avvicinare mani, piedi e capelli ai pezzi in movimento.

**WAARSCHUWING**

- Onjuist gebruik van dit product kan ernstige verwondingen veroorzaken.
- Vooraf u het product gaat gebruiken, moet u de gebruiksaanwijzing lezen en alle waarschuwingen en instructies die hij bevat toepassen.
- Deze machine niet door kinderen laten gebruiken en niet in de buurt ervan laten komen.
- Als de sticker beschadigd, onleesbaar of afwezig is, moet hij vervangen worden.
- Uw handen, voeten of haar niet in de buurt van de bewegende delen brengen.

**AVISO**

- Qualquer utilização imprópria deste produto comporta o risco de causar danos graves.
- Antes de cada utilização, leia atentamente as instruções de utilização e respeite o conjunto dos avisos e instruções incluídas.
- Mantenha este aparelho afastado das crianças e não permita a sua utilização por estas.
- Se o autocollante estiver danificado, ilegível ou ausente, é conveniente substituí-lo.
- Não aproxime as suas mãos, pés e cabelos das peças em movimento.

**UWAGA**

- Nieprawidłowe użytkowanie produktu może być przyczyną wypadków.
- Przeznaczaj instrukcję obsługi i przestrzegaj wszystkich zaleceń i instrukcji.
- Nie zezwalaj dzieciom na zabawę na i w pobliżu urządzenia.
- Wymień etykiety w przypadku uszkodzenia, niezczytelności lub ich braku.
- Nie zbliżaj ręk, nog i włosów do elementów w ruchu.

**FIGYELMEZTETÉS**

- A szerkezet helytelen használata súlyos sérülésekhez vezethet.
- Használat előtt olvassa el a felhasználói kézikönyvet és tartson be minden figyelmeztetést, illetve használati útmutatót!
- Ne hagyja, hogy a gyerekek a gépre vagy közelébe kerüljenek.
- Csereélje ki a címkéit, ha sérült, olvashatatlan vagy hiányzik.
- Tartsa távol a kezeit, lábakat, a haját a mozgó alka részekétől!

**Предупреждение**

- Некорректная эксплуатация данного изделия может вызвать тяжелые повреждения.
- Перед использованием внимательно прочитайте инструкцию по эксплуатации.
- Соблюдайте все предосторожности и рекомендации, которые содержат этот документ.
- Не позволяйте детям использовать эту машину. Не допускайте детей близко к аппарату.
- Если клейкая этикетка повреждена, стерта или отсутствует, ее необходимо заменить.
- Необходимо следить за тем, чтобы руки, ноги и волосы находились вдали от движущихся частей аппарата.

**ATENȚIE**

- Utilizarea necorespunzătoare a acestui produs riscă să provoace răni grave.
- Înainte de utilizare, vă rugăm să citiți cu atenție modul de folosire și să respectați toate
- Atenționările și instrucțiunile pe care acesta le conține.
- Nu permiteți copiilor să utilizeze această mașină și țineți-i departe de aceasta.
- Dacă autocollantul este deteriorat, ilizibil sau lipsește, este indicat să îl înlocuiți!
- Nu vă apropiați mâinile, picioarele și părul de piesele în mișcare.

**UPOZORNENIE**

- Akémakévk nehódné použití tohoto výrobku může způsobit vážné poranění.
- Před akýmákoliv použitím výrobku si starostlivo přečtíte návod na použití a respektujte všechno upozornění a pokyny, která jsou zde uvedena.
- Zabraňte dětem, aby tento přístroj používaly a přibližovaly se k němu.
- Jestliže je samolepicí štítek poškozen, je nečitelný nebo na výrobku chybí, je nutné jej vyměnit.
- Nepřibližujte ruce, nohy a vlasy k pohyblivým se součástkám.

**UPOZORNĚNÍ**

- Jakékoli nevhodné použití tohoto výrobku může způsobit vážná poranění.
- Před jakýmkoliv použitím výrobku si pečlivě přečtete návod k použití a respektujte všechno upozornění a pokyny, která jsou zde uvedena.
- Zabraňte dětem, aby tento přístroj používaly a přibližovaly se k němu.
- Jestliže je samolepicí štítek poškozen, je nečitelný nebo na výrobku chybí, je nutné jej vyměnit.
- Nepřibližujte ruce, nohy a vlasy k pohyblivým se součástkám.

**WARNING**

- Felalagb användning av denna produkt riskerar att förorsaka allvarliga personskador.
- Läs noga bruksanvisningen innan du använder produkten och ta hänsyn till alla varningar och instruktioner som den innehåller.
- Låt inte barn använda denna maskin och håll dem på avstånd från den.
- Om deklaren är skadad, oläslig eller saknas, måste den ersättas med en ny.
- Låt inte händerna, fötterna eller håret komma i närheten av rörliga delar.

**ПРЕДУПРЕЖДЕНИЕ:**

- Всяко неправилно използване на този продукт може да доведе до сериозни наранявания.
- Преди да използвате продукта, моля прочетете внимателно начина на употреба и спазвайте всички предупреждения и инструкции, които той съдържа.
- Не позволявайте тази машина да бъде използвана от деца и ги дръжте на разстояние от нея.
- Ако самозалепващата лента е повредена, нечетлива или липсва, тя трябва да бъде сменена.
- Не доближавайте ръцете, краката и косите си до движещите се части.

**UYARI**

- Bu ürünün herhangi bir yanlış kullanımı ağır yaralara yol açabilir.
- Her kullanımdan önce, kullanımı yönetimini dikkatle okumanız ve içindeki tüm uyarı ve talimatları uymanız gerekir.
- Cocukların bu makineyi kullanmalarına izin vermemeniz ve onları bu makineden uzak tutun.
- Yapışkan etiket zarar görmüş, okunaksız veya mevcut değilse, yenisi ile değiştirilmesi uygun olacaktır.
- Ellerinizi, ayaklarınızı ve saçlarınızı hareket halindeki parçalara yaklaştırmayın.

**ЗАСТЕРЕЖЕННЯ**

- Всяке не відповідне застосування виробу утворює ризик тяжких поранень.
- Перед застосуванням прочитайте інструкцію використання та дотримуйтеся усіх попереджень та порад, які вона містить.
- Не дозволяйте дітям користатися цим апаратом та не підпускайте їх близько до нього.
- Якщо наклеїва пошкоджена, нерозбірлива або відсутня, треба її замінити.
- Не наближайте руки, ноги та волосся до деталей, що рухаються.

**تحذير**

- عدم استخدام هذا المنتج بشكل سليم قد يسبب في إصابة خطيرة.
- قبل الاستخدام احرص على قراءة دليل الاستخدام بعناية مع الاهتمام الخاص بجميع التحذيرات والتعليمات التي يتضمنها.
- يمنع استخدامه من قبل الأطفال ويحفظ بعيداً عنهم.
- يجب استبدال اللاصقة إذا تلفت أو تشوهت أو فقتت.
- يمنع تقريب اليدين والقدمين والشعر من جميع الأجزاء المتحركة.

**注意**

- 濫用本产品有造成严重伤害的可能。
- 使用前請閱讀使用說明，遵守其中的有關注意事項和操作規定。
- 不要讓兒童使用本产品或在產品周圍玩耍。
- 若標籤受損、印刷模糊或無標籤，則應更換標籤。
- 使手、腳和头发远离运动的部位。

You have chosen a piece of fitness equipment by DOMYOS. We thank you for your confidence in us. We have created the DOMYOS brand to provide a way for all athletes to stay in shape. This product has been designed by athletes for athletes. We would be pleased to receive your comments and suggestions concerning DOMYOS products. Therefore, your store team is ready to listen, as is the DOMYOS products design department. You can also find us at [www.domyos.com](http://www.domyos.com).

We wish you successful training and hope that you will enjoy using this DOMYOS product.

## PRESENTATION

This piece of fitness equipment will help you to strengthen your abs, particularly your rectus and oblique muscles. It features:

- a frame to help you and guide your movement.
- a head rest, helping you to avoid using your cervical neck muscles too much.

## WARNING

Before beginning any exercise program, consult your doctor. This is especially important for people aged over 35 or who have previously had health problems, and those who have not done any sport for a number of years. Read all instructions before use.

## SAFETY

**To reduce the risk of serious injury, please read the following important user precautions before using the product.**

1. Read all the instructions in this manual before using the product. Only use this product in the manner described in this manual. Keep this manual for the entire life of the product.
2. This piece of equipment must be assembled by an adult.
3. The owner is responsible for ensuring that all users of this product are properly informed as to how to use this product safely.
4. DOMYOS cannot be held liable for claims of injury or damage sustained by any person or property originating from the use or misuse of this product by the purchaser or by any other person.
5. This product is intended for domestic use only. Do not use this product in a commercial, rental, or institutional setting.
6. Use the product indoors on a flat surface in a dry, dust-free uncluttered place. Ensure that you have enough space to access and move around the device safely. Protect the floor under the product by covering it.
7. Do not store this product in a damp place (e.g. edge of a pool, bathroom etc.)
8. It is the user's responsibility to inspect and if necessary tighten all parts before using the product. Immediately replace any worn or defective parts.
9. Wear athletic shoes to protect your feet while exercising. DO NOT wear loose or baggy clothing, since it may get caught in the machine. Take off all jewellery.
10. Put your hair up so that it does not get in the way during exercise.
11. If you feel any pain or if you become dizzy while exercising, stop immediately, rest, and consult a physician.
12. If you begin to feel your muscles tiring, rest for a moment before continuing. Do not tire your muscles out! This may wear you out or cause injury.
13. Keep children and pets away from the product at all times.
14. Keep your hands and feet away from moving parts.
15. Do not modify your product.
16. If your product deteriorates, do not use it any longer and take it to your Decathlon store.
17. Always warm up before exercising. Start training gently and set yourself realistic goals.
18. While exercising, maintain continuous, regular movements.
19. Any assembly or disassembly of the product should be carried out with care.

## USE

### TRAINING:

If you are not an athlete, follow the beginners exercise programme for the first 3 to 4 weeks of your training. With regard to breathing, you should breathe out while taking the strain and breathe in while returning to the starting position. You therefore breathe out when you contract your abs and breathe in when relaxing them. Time your breathing to match the rhythm of your exercise so you don't get out of breath. Vary the order of your exercises so that your abs do not get used to a particular pace or exercise order.

Add aerobic exercise like walking, running, swimming or cycling to your training programme. Give your muscles at least one day's rest a week between consecutive training sessions. It is important to isolate your abdominal muscles and work on them with controlled movements. You should aim to do 3 to 4 series of each exercise, with 15 to 20 repetitions per series.

### BEGINNERS LEVEL:

Warm up with a series of 10 repetitions.  
Rest for 30 seconds.  
Restart with a series of 12 repetitions.  
Rest for 30 seconds.  
Restart with a series of 15 repetitions.  
Rest for 30 seconds to one minute before moving onto another exercise.  
Do three exercises from the list.

### INTERMEDIATE LEVEL:

Warm up with a series of 12 repetitions.  
Rest for 10 to 15 seconds.  
Then do 15 repetitions.  
Rest for less than 10 seconds.  
Series of 15 repetitions.  
During the last five repetitions, slow your speed while concentrating on contracting your muscles.  
For these last 5 repetitions, remain in a high position (abs contracted) for 5 seconds.  
Rest for 30 seconds before moving onto another exercise.  
Do three exercises from the list.

### ADVANCED LEVEL:

Warm up with a series of 15 repetitions.  
Rest for 10 seconds.  
Do a second series of 15 repetitions.  
For the last five repetitions, remain in a high position for 5 seconds, then move back down very slowly to your starting position (count 5 seconds before you are back in position).  
Rest for 15 seconds.  
Complete a third series of 20 repetitions with the final five in position of maximum contraction (stopping in high position, returning slowly back down). Rest for 15 seconds.  
The last series of the exercise should be a maximum-effort series. Do as many repetitions as possible while you can complete the exercise properly, and contract your abs.  
Rest for 30 seconds.  
Go to the next exercise.  
Do three exercises from the list.

## MAINTENANCE

The product only requires minimal maintenance. Clean it using a sponge soaked in soapy water and dry it using a dry cloth. Check regularly that all screws are tight.

## WARRANTY

DOMYOS guarantees the materials and workmanship of this product under normal conditions of use for 5 years starting at the date of purchase as indicated by the date on the cash register receipt.

DOMYOS obligation with regard to this guarantee is limited to the replacement or repair of the product, at the discretion of DOMYOS.

All products for which the warranty is applicable must be received by DOMYOS at one of its approved facilities, delivery prepaid, accompanied by adequate proof of purchase.

This warranty does not apply to cases of:

- Damage caused during transport.
- Use and/or storage outside or in a wet environment.
- Poor assembly.
- Improper or abnormal use.
- Poor maintenance.
- Repairs made by technicians not approved by DOMYOS.
- Use in a non-domestic setting.

This warranty does not exclude any legal guarantees applicable according to country and/or province.

**OXYLANE** - 4 BOULEVARD DE MONS - BP299 - 59665 VILLENEUVE D'ASCQ Cedex - France